

GRAEME FINLAY

Evolution as created history

The science of biological evolution continues to arouse debate. In this paper, I wish to show how the distribution of endogenous retroviruses and transposons in mammalian genomes demonstrates that humans have evolved from progenitors that are ancestral to all apes, primates, and mammals. New genes and gene families have risen from ongoing natural genetic processes.¹ The evolutionary understanding of biological history is compatible with the historical basis of biblical faith. It is suggested that Christians should see biological evolution as Israel understood her chaotic and tumultuous story: created history.

Keywords: Evolution; genomics; creation; mammals; eschatology.

The human genome consists of two sets of chromosomes, with twenty-three chromosomes in each set. Each chromosome contains one DNA molecule, a linear polymer of linked units called nucleotides. Each set of twenty-three DNA molecules is composed of ~3 billion nucleotides. Each nucleotide possesses one of four bases: adenine (A), cytosine (C), guanine (G) and thymine (T), the units of genetic information.

Half of the DNA in the human genome has been added in discrete units. These readily identifiable units are parasitic, self-propagating segments of DNA, of which over three million have been counted. They include retroviruses that invade cells and insert their DNA into that of the infected cell, and ‘transposons’ (mobile elements, or transposable elements, TEs). Most of these TEs are called ‘retrotransposons’. They do not travel between cells, but track from one generation to the next as part of the cells’ DNA, copying and pasting themselves as they go.²

Cells express their genetic material by copying DNA into the related polymer RNA (‘transcription’), trimming and modifying the RNA transcript (‘processing’) and then using the genetic information in RNA to assemble proteins. Retroviruses and retrotransposons propagate themselves by producing enzymes that subvert this mechanism. A ‘reverse transcriptase’ copies their RNA transcript back into DNA. An ‘endonuclease’ cuts chromosomal DNA, making a gap into which the parasitic segment of DNA is inserted (thereby

1 Extending work reviewed by Finlay, G.J. ‘*Homo divinus*: the ape that bears God’s image’, *Science and Christian Belief* (2003) 15, 17.

2 For reviews, see Deininger, P.L., Moran, J.V., Batzer, M.A. and Kazazian, H.A. ‘Mobile elements and mammalian genome evolution’, *Curr Opin Genet Dev* (2003) 13, 651; Kazazian, H.H. ‘Mobile elements: drivers of genome evolution’, *Science* (2004) 303, 1626; Hedges, D.J. and Batzer, M.A. ‘From the margins of the genome: mobile elements shape primate evolution’, *Bioessays* (2005) 27, 785.

becoming part of the genome of the host cell; Figure 1). During this process, small telltale duplications of the targeted DNA are generated ('target site duplications', TSDs).

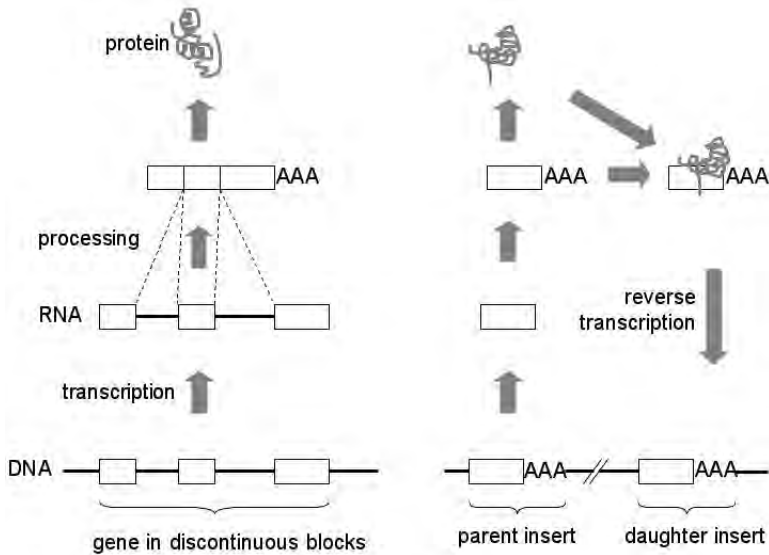

Figure 1. A comparison of transcription (in normal protein synthesis, left), and reverse transcription (in the proliferation of parasitic elements, right).

Segments of retroviral and transposon DNA insert into cellular DNA at sites loosely preferred by the endonuclease, but that are otherwise chosen largely at random. Genomes are so large that a vast number of sites can accept new inserts, and new parasites freely insert into old ones. The propagation of retroviruses³ and the copying and pasting of retrotransposons have been studied in cultured cells⁴ and in mice,⁵ demonstrating that these agents operate randomly as insertional mutagens.

3 Dewannieux, M., Harper, F., Richaud, A. et al. 'Identification of an infectious progenitor for the multiple-copy HERV-K human endogenous retroelements', *Genome Res* (2006) 16, 1548; Lee, Y.N. and Bieniasz, P.D. 'Reconstruction of an infectious human endogenous retrovirus', *PLoS Pathogens* (2007) 3, 119.

4 Stenglein, M.D. and Harris, R.S. 'APOBEC3B and APOBEC3F inhibit L1 retrotransposition by a DNA deamination-independent mechanism', *J Biol Chem* (2006) 281, 16837; Bogerd, H.P., Wiegand, H.L., Hulme, A.E. et al. 'Cellular inhibitors of long interspersed element 1 and Alu retrotransposition', *Proc Natl Acad Sci USA* (2006) 103, 8780; Chiu, Y.-L., Witkowska, H.E., Hall, S.C. et al. 'High-molecular-mass APOBEC3G complexes restrict Alu retrotransposition', *Proc Natl Acad Sci USA* (2006) 103, 15588.

5 An, W., Han, J.S., Wheelan, S.J. et al. 'Active retrotransposition by a synthetic L1 element in mice', *Proc Natl Acad Sci USA* (2006) 103, 18662.

Insertions may occur in somatic (non-reproductive) cells. These have the potential to cause cancers. Some human leukaemias arise naturally from the 'human T cell leukaemia virus',⁶ and artificially from engineered retroviruses used in gene therapy.⁷ In any one cancer, all the cancer cells possess precisely the same retroviral insert, because they have all inherited that insert from the one virus-deranged cell that gave rise to the cancer.

Insertions may occur also in germ-line (reproductive) cells. TEs are added to the human gene pool at a frequency of one new insert every 10 births.⁸ Their activity as insertional mutagens is apparent when they inactivate genes and cause devastating genetic diseases.⁹ These disease-causing inserts may become widespread in certain populations. Each insert exists in a characteristic genetic environment, indicating that one unique founder mutation has spread in the population. Everyone who possesses the unique insert has inherited it from the individual in which the insert occurred.¹⁰

It follows that when a particular insert is found in multiple species, those species must be descendants of the one species (indeed the one reproductive cell)

6 Karpas, A. 'Human retroviruses in leukaemia and AIDS: reflections on their discovery, biology and epidemiology', *Biol Revs Camb Philos Soc* (2005) 79, 911; Mortreux, F., Gabet, A.-S. and Wattel, E. 'Molecular and cellular aspects of HTLV-1 associated leukemogenesis in vivo', *Leukemia* (2003) 17, 26; Tsukasaki, K., Koeffler, P. and Tomonaga, M. 'Human T-lymphotropic virus type I infection', *Best Pract Res Clin Haematol* (2000) 13, 231.

7 Hacein-Bey-Abina, S., Von Kalle, C., Schmidt, M. et al. 'LMO2-associated clonal T cell proliferation in two patients after gene therapy for SCID- X1', *Science* (2003) 302, 415.

8 Cordaux, R., Hedges, D.J., Herke, S.W. and Batzer, M.A. 'Estimating the retrotransposition rate of human *Alu* elements', *Gene* (2006) 373, 134. This figure is based on a frequency of new *Alu* and *LINE-1* inserts, each at 1 in 20 births.

9 Chen, J.-M., Stenson, P.D., Cooper, D.N. and Ferec, C. 'A systematic study of *LINE-1* endonuclease-dependent retrotranspositional events causing human genetic disease', *Hum Genet* (2005) 117, 411; Chen, J.-M., Ferec, C. and Cooper, D.N. 'LINE-1 endonuclease-dependent retrotranspositional events causing human genetic disease: mutation detection bias and multiple mechanisms of target gene disruption', *J Biomed Biotechnol* (2006) 2006, 1 (Article ID 56182); Callinan, P.A. and Batzer, M.A. 'Retrotransposable elements and human disease', *Genome Dyn* (2006) 1, 104. For recent examples, see Mine, M., Chen, J.-M., Brivet, M. et al. 'A large genomic deletion in the *PDHx* gene caused by the retrotranspositional insertion of a full-length *LINE-1* element', *Hum Mutat* (2007) 28, 137; Claverie-Martin, F., Flores, C., Gonzalez-Acosta, H. et al. 'The *Alu* insertion in the *CLCN5* gene of a patient with Dent's disease leads to exon 11 skipping', *J Hum Genet* (2005) 50, 370; Apoil, P.A., Kuhllein, E., Robert, A. et al. 'HIGM syndrome caused by an insert of an *AluYb8* element in exon 1 of the *CD40LG* gene', *Immunogenetics* (2007) 59, 17; Ostertag, E.M., Goodier, J.L., Zhang, Y. and Kazazian, H.H. 'SVA elements are nonautonomous retrotransposons that cause disease in humans', *Am J Hum Genet* (2003) 73, 1444.

10 Watanabe, M., Kobayashi, K., Jin, F. et al. 'Founder SVA retrotranspositional insertion in Fukuyama-type congenital muscular dystrophy and its origin in Japanese and northeast Asian populations', *Am J Med Genet Part A* (2005) 138A, 344. Disruption of a gene by insertion an SVA element causes neurological disease in Japanese populations. This insertion is present at a frequency of ~0.5% of these populations. Because the insert is the same in all those who have the element, it is accepted that it arose in a unique event (estimated to be ~2-2.5 thousand years ago). Everyone who now possesses the element received it by inheritance from the original founder. See also Bouchet, C., Vuillaumier-Barrot, S., Gonzales, M. et al. 'Detection of an *Alu* insertion in the *POMT1* gene from three French Walker Warburg syndrome families', *Molec Genet Metab* (2007) 90, 93.

in which that unique insert occurred. It is exceedingly unlikely that a parasite would insert into the same site independently in two (or more) species. In large surveys of human-specific TEs, independent insertions into the same genetic sites of other species by TEs specific to those species have not been observed.¹¹

An ERV insert that originated in an ape ancestor¹²

human, chimp, gorilla	...CAATTATCTTGCAAC[ERV-WE1]CAACCATG...
orang	...CAATTATCTTGCAAC[ERV-WE1]CAATCATG...
gibbon	...CAATTATCTTGCAAC[ERV-WE1]CAACCATG...
two NWM species	...CAATTATCTTGCAAC CATG...
prosimian species	...CCACCATCTTGCAAA TATG...
dog	...CAACCATCTTGCAAA TGTG...

A LINE insert that originated in an ape-OWM ancestor¹³

human	...AGTTCTGC[TCTAA...AAA T] GCAGACATC...
chimp	...AGTTCTGC[TCTAA...AAA T] GCAGACCTC...
gorilla	...AGTTCTGC[TCTAA...AAA T] GCAGACATC...
orang	...AGTTCTGC[TCTAA...AAAAT] CCAGACATC...
three OWM species	...AGTTCTGC[TCTAA...AAA Δ] ΔΔΔΔΔATC...

An Alu insert that originated in a great ape ancestor¹⁴

human, chimp, gorilla	...AAAAAAGTAGCC[Alu]TAGCCTGTTTCTT...
orang	...AAAAAAGTAGCC[Alu]TAGCCTGTTTCTT...
baboon (OWM)	...AAAAAAGTAGCC TGTTTCTT...
two macaque species (OWM)	...AAAAAAGTAGCC TGTTTCTT...

The GLUD2 retrogene insert that originated in an ape ancestor¹⁵

human, chimp, gorilla	...GAAGTATAGAACAAACAG[GLUD2]ATAGAACAAATAATG...
orang, gibbon	...GAAGTATAGAACAAACAG[GLUD2]ATAGAACAAATAATG...
OWM	...GAAGTATAGAACAAA TAATG...

Figure 2. Inserted elements demonstrating common ancestry of humans and other primates. Equivalent short stretches of DNA sequence are shown for different species. The letters A, C, G, and T represent bases, which are the units of genetic information, arranged in a linear sequence along DNA. Square brackets: the location of an inserted element; underlined bases: target sites and their duplications that arise during the insertion process; (: deleted bases; NWM: New World Monkey; OWM: Old World Monkey. The ERV-WE1 is present also in OWMs, but sequence data are not available.

11 Vincent, B.J., Myers, J.S., Ho, H.J. et al. 'Following the LINEs: an analysis of primate genomic variation at human-specific LINE-1 insertion sites', *Mol Biol Evol* (2003) 20, 1338; Ho, H.J., Ray, D.A., Salem, A.-H. et al. 'Straightening out the LINEs: LINE-1 orthologous loci', *Genomics* (2005) 85, 201; Roy-Engel, A.M., Carroll, M.L., El-Sawy, M. et al. 'Non-traditional Alu evolution and primate genomic diversity', *J Mol Biol* (2002) 316, 1033.

Primate history

The route of human evolutionary history has been delineated by the distribution in primate genomes of inherited parasitic inserts (Figure 2). The sequences include retroviral inserts or 'endogenous retroviruses' (ERVs), that constitute 8% of our genome, and TEs that are of two main categories.

- 'Long interspersed elements' (LINEs) are parasites of unknown origin. They possess genes that encode enzymes needed for their propagation. 'LINE-1' elements are the most abundant type of LINE in human DNA, and they constitute 17% of our genome. Many LINE-1 segments lack TSDs and may have arisen as repair patches at DNA breaks.¹⁶
- 'Short interspersed elements' (SINEs) co-opt the proteins made by LINEs in order to propagate themselves. The most abundant SINEs in the human genome are the primate-specific Alu elements, originally derived from a small cellular gene. They contribute 11% of our genome.¹⁷

Normal cellular RNA molecules may also become entwined in the enzymatic machinery of LINE-1 elements and become spliced back into chromosomal DNA. These unscheduled events generate inserts called 'processed pseudogenes' (that lack the ability to generate proteins) or 'retrogenes' (that retain this ability). There are >8,000 of these in the human genome.¹⁸

Systematic studies of such inserts have delineated the route of human evolution

12 Bonnaud, B., Beliaeff, J., Bouton, O. et al. 'Natural history of the ERVWE1 endogenous retroviral locus', *Retrovirology* (2005) 2, 57; Caceres, M., NISC Comparative Sequencing Program and Thomas, J.W. 'The gene of retroviral origin syncytin 1 is specific to hominoids and is inactive in Old World Monkeys', *J Hered* (2006) 97, 100.

13 Schueler, M.G., Dunn, J.M., Bird, C.P. et al. 'Progressive proximal expansion of the primate X chromosome centromere.' *Proc Natl Acad Sci USA* (2005) 102, 10563. A particular 7-base deletion shared by the OWMs demonstrates descent from a unique OWM ancestor in which the deletion occurred.

14 Gibbons, R. and Dugaiczky, A. 'Phylogenetic roots of Alu-mediated rearrangements leading to cancer', *Genome* (2004) 48, 160.

15 Burki, F. and Kaessmann, H. 'Birth and adaptive evolution of a hominoid gene that supports high neurotransmitter flux', *Nature Genet* (2004) 36, 1067.

16 Babushok, D.V. and Kazazian, H.H. 'Progress in understanding the biology of the human mutagen LINE-1', *Hum Mutat* (2007) 28, 527; Khan, H., Smit, A. and Boissinot, S. 'Molecular evolution and tempo of amplification of human LINE-1 retrotransposons since the origin of primates', *Genome Res* (2006) 16, 78; Zingler, N., Willhoeft, U., Brose, J.-P. et al. 'Analysis of 5' junctions of human LINE-1 and *Alu* retrotransposons suggests an alternative model for 5'-end attachment requiring microhomology-mediated end-joining', *Genome Res* (2005) 50, 780; Morrish, T.A., Gilbert, N., Myers, J. et al. 'DNA repair mediated by endonuclease-independent LINE-1 retrotransposition', *Nature Genet* (2002) 31, 158.

17 Ray, D.A. 'SINEs of progress: mobile element applications to molecular ecology', *Molecular Ecology* (2007) 16, 19; Price, A.L., Eskin, E. and Pevzner, P.A. 'Whole-genome analysis of *Alu* repeat elements reveals complex evolutionary history', *Genome Res* (2004) 14, 2245.

18 Pavlicek, A., Gentles, A.J., Paces, J. et al. 'Retroposition of processed pseudogenes: the impact of RNA stability and translational control', *Trends Genet* (2006) 22, 69; Ding, W., Lin, L., Chen, B. and Dai, J. 'L1 elements, processed pseudogenes and retrogenes in mammalian genomes', *IUBMB Life* (2006) 58, 677.

Table 1. Analysis of inserts in three primate species¹⁹

type of insert	number of inserts that are			
	present in the human genome	present only in human	shared with chimp	shared with macaque
ERV	500,000	200	500,000	great majority
LINE-1	570,000	2,000	570,000	>500,000
LINE-2	360,000	few if any	essentially all	essentially all
MIR	580,000	few if any	essentially all	essentially all
Alu	1,100,000	7,000	1,100,000	1,000,000
SVA	3,400	970	1,800	100
DNA transposon	360,000	few if any	essentially all	essentially all

from primate progenitors. Firstly, whole genome comparisons have been performed on sequenced genomes. Comparison of the human and chimp genomes shows that >99% of the individual ERV, LINE and SINE elements in the human genome are present also in the chimp genome. Human and chimp genomes share three million inserts (Table 1). The few that are not shared are recent additions. The small population of SVA elements is a case in point. SVA elements appeared only in the apes, and are currently copying and pasting themselves actively. Even so, ~65% of SVA inserts are shared with chimps, a sufficient demonstration of common ancestry.²⁰

Two Alu elements can interact with each other ('recombine') in such a way that the intervening sequence is spliced out and lost.²¹ This happens in somatic cells to cause oncogenic mutations,²² and in germ cells to cause heritable deletions. Genome comparisons have identified ~500 instances in which two Alu elements preserved in the chimp genome have precisely recombined to generate one chimaeric Alu element (with loss of the intervening DNA) in the human

19 International Human genome Sequencing Consortium. 'Initial sequencing and analysis of the human genome', *Nature* (2001) 401, 860; The Chimpanzee Sequencing and Analysis Consortium. 'Initial sequence of the chimpanzee genome and comparison with the human genome', *Nature* (2005) 437, 69; Polavarapu, N., Bowen, J. and McDonald, J.F. 'Identification, characterization, and comparative genomics of chimpanzee endogenous retroviruses', *Genome Biology* (2006) 7, R51; Romano, C.M., Ramalho, R.F. and de A. Zanotto, P.M. 'Tempo and mode of ERV-K evolution in human and chimpanzee genomes.' *Arch Virol* (2006) 151, 2215; Mills, R.E., Bennett, E.A., Iskow, R.C. et al. 'Recently mobilized transposons in the human and chimpanzee genomes', *Am J Hum Genet* (2006) 78, 671; Wang, H., Xing, J., Grover, D. et al. 'SVA elements: a hominid-specific retroposon family', *J Mol Biol* (2005) 354, 994; Rhesus Macaque Genome Sequencing and Analysis Consortium 'Evolutionary and biomedical insights from the rhesus macaque genome', *Science* (2007) 316, 222; Han, K., Konkel, M.K., Xing, J. et al. 'Mobile DNA in Old World Monkeys: a glimpse through the rhesus macaque genome', *Science* (2007) 316, 238.

20 Wang, Xing, Grover et al. *op. cit.*, (19).

21 For the textual critic, we could call this 'molecular haplography'; for the biologist this is 'non-allelic homologous recombination'.

22 Gibbons and Dugaiczkyk *op. cit.*, (14).

genome.²³ This phenomenon illustrates how ancestral genomes are transformed into current genomes by natural genetic process.

Analysis of the draft sequence of a more distant relative, the rhesus macaque (an Old World Monkey, OWM) has shown that the great majority of ERV and TE inserts is shared by humans and OWMs, even though a large number of new lineage-specific inserts have accumulated (Table 1). The one exception is the SVA class of TE, where only about 100 of the forerunners of this class are present in macaque, and 80 of these are shared with humans.²⁴

Multi-species genome comparisons are available for some genes. Sequence analysis of the *ASPM* and *BRCA1* genes reveals haphazard arrays of ERVs and TEs that are shared by numerous species.²⁵ This anticipates the mass of confirmatory data that will be available as further primate genome sequences are analysed.

The second systematic approach to establishing the pattern of primate evolution involves determining the distribution of individual inserts in the genomes of multiple primate species. The distribution of ~70 LINE-1 elements, restricted to ape genomes, shows a fully consistent family tree (Figure 3).²⁶ Some are present in humans only; others in humans and the two chimp species only; others in humans, chimps and gorillas only; and some in the genomes of all the great apes including orangutans. All species sharing a particular LINE-1 element are monophyletic (descended from the one ancestor in which that element was inserted).

LINE-1 elements provide other cogent evidence of common ancestry. During the copying of LINE-1 RNA into DNA, the reverse transcriptase can switch from the LINE-1 RNA and start copying a bystander RNA molecule. The resulting insert will be a chimaera: part-LINE-1, part-bystander RNA, joined at a unique point. One such element contains 476 bases of LINE-1 sequence, 40 bases of an ERV, and 40 bases of cellular DNA. This unique chimaera is present in humans, chimps and bonobos.²⁷ Over 80 of these singular patchwork inserts exist in

23 Sen, S.K., Han, K., Wang, J. et al. 'Human genomic deletions mediated by recombination between *Alu* elements', *Am J Hum Genet* (2006) 79, 41.

24 Rhesus Macaque Genome... Consortium *op. cit.*, (19); Han, Konkel, Xing et al. *op. cit.*, (19).

25 Kouprina, N., Pavlicek, A., Mochida, G.H. et al. 'Accelerated evolution of the *ASPM* gene controlling brain size begins prior to human brain expansion', *PLoS Biology* (2004) 2, 653; Pavlicek, A., Noskov, V.N., Kouprina, N. et al. 'Evolution of the tumour suppressor *BRCA1* locus in primates: implications for cancer predisposition', *Hum Mol Genet* (2004) 13, 2737; Shibuya, K., Kudoh, J., Obayashi, I. et al. 'Comparative genomics of the keratin-associated protein (KAP) gene clusters in human, chimpanzee, and baboon', *Mammalian Genome* (2004) 15, 179.

26 Mathews, L.M., Chi, S.Y., Greenberg, N. et al. 'Large differences between LINE-1 amplification rates in the human and chimpanzee lineages', *Am J Hum Genet* (2003) 72, 739.

27 Ling, J., Zhang, L., Jin, H. et al. 'Dynamic retrotransposition of ERV-9 LTR and L1 in the β -globin gene locus during primate evolution', *Molecular Phylogenet Evol* (2004) 30, 867.

human DNA, and many are shared with other species (Figure 3).²⁸

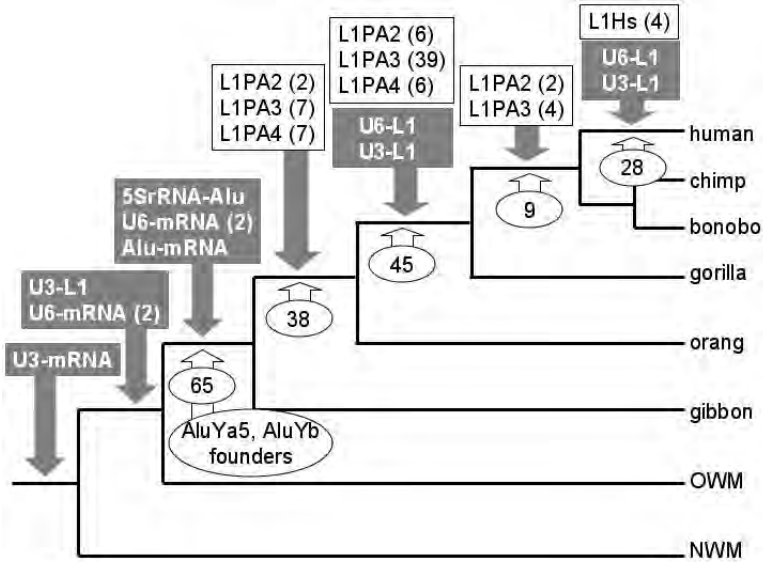

Figure 3. Primate evolutionary relationships as determined by the distribution of transposable elements. Insertions of LINE-1 elements (unshaded boxes)²⁹ and uniquely structured chimaeric elements (grey boxes)³⁰ arose in the primate germ-line when indicated. Numerals in parenthesis indicate the numbers of individual elements included in the analysis. The times at which Alu elements (of the AluYe and AluYd3 subtypes) inserted into primate DNA are indicated by ovals.³¹ Numerals indicate the number of elements studied. The founders of two Alu families that have expanded recently in humans (AluYa5 and AluYb) were inserted into the DNA of an ape ancestor.

Some 7,000 Alu elements are found only in humans. Many of these have entered the human germ-line so recently that many people lack the inserted

28 Chimaeras comprise portions of LINE-1 and Alu elements, small nuclear RNAs, messenger RNAs, and ribosomal RNAs. Buzdin, A., Ustyugova, S., Gogvadze, E. et al. 'A new family of chimeric retrotranscripts formed by a full copy of U6 small nuclear RNA fused to the 3' terminus of L1', *Genomics* (2002) 80, 402; Buzdin, A., Gogvadze, E., Kovalskaya, E. et al. 'The human genome contains many types of chimeric retrogenes generated through *in vivo* RNA recombination', *Nucleic Acids Res* (2003) 31, 4385; Gogvadze, E.V., Buzdin, A.A. and Sverdlov, E.D. 'Multiple template switches on LINE-directed reverse transcription: the most probable formation mechanism for the double and triple chimeric retroelements in mammals', *Russ J Bioorg Chem* (2005) 31, 74.

29 Mathews, Chi, Greenberg, et al. *op. cit.*, (26).

30 Ling, Zhang, Jin, et al. *op. cit.* (27).

31 see above (28).

element.³² For example, the AluYa5 and AluYb families are currently expanding in the human genome, although each arose from a founder element that inserted into the DNA of an ape ancestor. Potentially active Alu elements can lie in wait for a million generations, poised to become active when conditions become permissive (Figure 3).³³

Other families of Alu inserts are distributed through the genomes of the apes. In studies of two such families, some elements were identified in humans and chimps only, others in humans, chimps and gorillas, others in humans, chimps, gorillas and orangutans, and others in all the apes including gibbons. The apes are monophyletic – clonally derived from each progenitor cell that sustained the DNA insertion of one of these Alu elements (Figure 3).³⁴ Most Alu elements in the human genome arose distantly in evolution and are shared by all simian species. The distribution of Alu elements has delineated the phylogenetic development also of the OWMs, NWMs and prosimians.³⁵

Insertional mutagens might be expected to have a preponderantly harmful effect. However, ERVs have been recruited repeatedly to perform genetic functions. Sequences in ERVs regulate the activity of nearby genes,³⁶ or contribute to the coding capacity of genes.³⁷ In several cases, an ERV *envelope* gene (part

32 Cordaux, R., Lee, J., Dinoso, L. and Batzer, M.A. 'Recently integrated *Alu* retrotransposons are essentially neutral residents of the human genome', *Gene* (2006) 373, 138; Garber, R.K., Hedges, D.J., Herke, S.W. et al. 'The *Alu* Yc1 subfamily: sorting the wheat from the chaff', *Cytogenet Genome Res* (2005) 110, 537; Han, K., Xing, J., Wang, H. et al. 'Under the genomic radar: the stealth model of *Alu* amplification', *Genome Res* (2005) 15, 655; Salem, A.-H., Kilroy, G.E., Watkins, W.S. et al. 'Recently integrated *Alu* elements and human genomic diversity', *Mol Biol Evol* (2003) 20, 1349.

33 Shaikh, T.H. and Deininger, P. 'The role and amplification of the HS *Alu* subfamily founder gene', *J Mol Evol* (1996) 42, 15 [HS elements are now called AluYa5]; Han et al. (2005), ref. 29; for a discussion about *Alu* master elements, see Cordeaux, R., Hedges, D.J. and Batzer, M. 'Retrotransposition of *Alu* elements: how many sources?' *Trends Genet* (2004) 20, 464.

34 Xing, J., Salem, A.-H., Hedges, D.J. et al. 'Comprehensive analysis of two *Alu* Yd subfamilies', *J Mol Evol* (2003) 57, S76; Salem, A.-H., Ray, D.A., Xing, J. et al. '*Alu* elements and hominid phylogenetics', *Proc Natl Acad Sci USA* (2003) 100, 12787; Salem, A.-H., Ray, D.A., Hedges, D.A. et al. 'Analysis of the human *Alu* Ye lineage', *BMC Evol Biol* (2005) 5, 18.

35 Xing, J., Wang, H., Han, K. et al. 'A mobile element based phylogeny of Old World monkeys', *Molec Phylogenet Evol* (2005) 37, 872; Ray, D.A., Xing, J., Hedges, D.J. et al. '*Alu* insertion loci and platyrrhine primate phylogeny', *Molec Phylogenet Evol* (2005) 35, 117; Roos, C., Schmitz, J. and Zischler, H. 'Primate jumping genes elucidate strepsirrhine phylogeny', *Proc Natl Acad Sci USA* (2004) 101, 10650; Herke, S. W., Xing, J., Ray, D.A. et al. 'A SINE-based dichotomous key for primate identification', *Gene* (2007) 390, 39; reviewed by Schmitz, J., Roos, C. and Zischler, H. 'Primate phylogeny: molecular evidence from retrotransposons', *Cytogenet Genome Res* (2005) 108, 26.

36 Bieche, I., Laurent, A., Laurendreau, I. et al. 'Placenta-specific *INSL4* expression is mediated by a human endogenous retroviral element', *Biol Reprod* (2003) 68, 1422; Dunn, C.A., van de Lage-maat, L.N., Baillie, G.J. and Mager, D.L. 'Endogenous provirus long terminal repeats as ready-to-use mobile promoters: the case of primate β *GAL-T5*', *Gene* (2005) 364, 2; Dunn, C.A., Romanish, M.T., Gutierrez, L.E. et al. 'Transcription of two human genes from a bidirectional endogenous retrovirus promoter', *Gene* (2006) 366, 335.

37 Huh, J.-W., Kim, T.-H., Yi, J.-M. et al. 'Molecular evolution of the periphilin gene in relation to human endogenous retrovirus M element', *J Mol Evol* (2006) 62, 730. The function of this gene has been influenced also by two other inserted parasitic sequences that date from before the divergence of the simians and prosimians.

of the retrovirus infection apparatus) has been co-opted to serve in the development of the placenta. The retroviruses involved entered the primate germline in ancestors of the simians³⁸ and of the OWM-ape group.³⁹ The redeployment of ERV *envelope* genes to serve the host organism has been observed also with ERVs of mice and sheep. In the latter case, experimental inhibition of *envelope* gene function terminated pregnancy.⁴⁰ Random insertional mutations have been selected to provide essential genetic functionality.

TEs also have been recruited to provide novel genetic function.⁴¹ A family of new genes was produced when an SVA element repeatedly copied-and-pasted itself, together with an adjacent gene, in an ancestor of the African great apes.⁴² TEs known as 'DNA transposons' (all of which are shared by humans and OWMs, Table 1) have given rise to many new genes, including the *SET-MAR* gene that arose from the insertion of an element in an ancestor of the simian primates.⁴³

Multiple classes of processed pseudogenes and retrogenes exist. Their dis-

38 Blaise, S., de Parseval, N., Benit, L. and Heidmann, T. 'Genomewide screening for fusogenic human endogenous retrovirus envelopes identifies syncytin 2, a gene conserved on primate evolution', *Proc Natl Acad Sci USA* (2003) 100, 13013; Malassine, A., Blaise, S., Handschuh, K. et al. 'Expression of the fusogenic HERV-FRD env glycoprotein (syncytin 2) in human placenta is restricted to villous cytotrophoblastic cells', *Placenta* (2007) 28, 185.

39 Aagaard, L., Villesen, P., Kjeldbjerg, A.L. and Pedersen, F.S. 'The ~30 million-year-old ERVPb1 envelope gene is evolutionarily conserved among hominoids and Old World monkeys', *Genomics* (2005) 86, 685; Herve, C.A., Forrest, G., Lower, R. et al. 'Conservation and loss of the *ERV3* open reading frame in primates', *Genomics* (2004) 83, 940; Kim, H.-S., Yi, J.-M., Hirai, H. et al. 'Human endogenous retrovirus (HERV)-R family in primates: chromosomal location, gene expression, and evolution', *Gene* (2006) 370, 34; Mallet, F., Bouton, O., Prudhomme, S. et al. 'The endogenous locus ERVWE1 is a bona fide gene involved in hominoid placental physiology', *Proc Natl Acad Sci USA* (2004) 101, 1731; Bonnaud, B., Bouton, O., Oriol, G. et al. 'Evidence of selection on the domesticated ERVWE1 *env* retroviral element involved in placentation', *Mol Biol Evol* (2004) 21, 1895. This ERV has a 12-base deletion (present in all species that possess it) that enhances its ability to induce cell fusion. This deletion has been demonstrated in 8 OWM species and 6 hominoid species. It is a marker of common ancestry. Prudhomme, S., Oriol, G. and Mallet, F. 'A retroviral promoter and a cellular enhancer define a bipartite element which controls *env* ERVWE1 placental expression', *J Virol* (2004) 78, 12157; Muir, A., Lever, A.M.L. and Moffett, A. 'Human endogenous retrovirus-W envelope (syncytin) is expressed in both villous and extravillous trophoblast populations', *J Gen Virol* (2006) 87, 2067.

40 Dunlap, K.A., Palmarini, M., Varela, M. et al. 'Endogenous retroviruses regulate preimplantation placental growth and differentiation', *Proc Natl Acad Sci USA* (2006) 103, 14390.

41 Hasler, J. and Strub, K. '*Alu* elements as regulators of gene expression', *Nucleic Acids Res* (2006) 34, 5491.

42 King, J., Wang, H., Belancio, V.P. et al. 'Emergence of primate genes by retrotransposon-mediated sequence transduction', *Proc Natl Acad Sci USA* (2006) 103, 17608.

43 Pace, J.K.II, Feschotte, C. 'The evolutionary history of human DNA transposons: evidence for intense activity in the primate lineage', *Genome Res* (2007) 17, 422; Cordaux, R., Udit, S., Batzer, M.A. and Feschotte, C. 'Birth of a chimeric primate gene by capture of the transposase gene from a mobile element', *Proc Natl Acad Sci USA* (2006) 103, 8101; Piriyaopongsa, J. and Jordan, I.K. 'A family of human microRNA genes from miniature inverted-repeat transposable elements', *PLoS One* (2007) 2, e203; domestication of genetic information from mobile elements is a recurring theme: see Volff J.-N. 'Turning junk into gold: domestication of transposable elements and the creation of new genes in eukaryotes', *BioEssays* (2006) 28, 913.

tribution yields a primate family tree that is wholly concordant with that revealed by TEs.⁴⁴ An example of a mutational event that generated genetic functionality is the glutamate dehydrogenase (*GLUD2*) retrogene for which the insertion site is shown in Figure 2.⁴⁵ New retrogenes have arisen by insertional mutagenesis repeatedly through primate history (Figure 4).⁴⁶

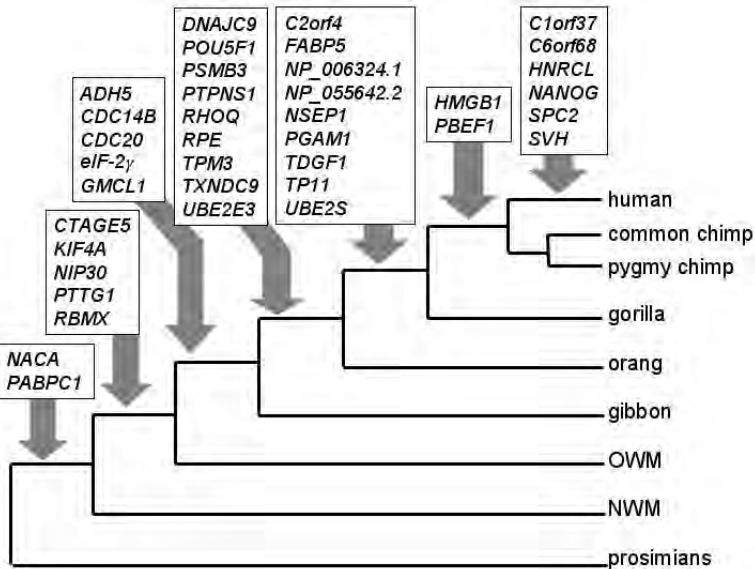

Figure 4. Primate evolution as determined by the distribution of reverse-transcribed retrogenes.⁴⁷

Mammalian history

Placental mammals have been classified into four groups, based on statistical analysis of aligned DNA sequences: Euarchontoglires (primates, flying lemurs,

44 Schmitz, J., Churakov, G., Zischler, H. and Brosius, J. 'A novel class of mammalian-specific tail-less retropseudogenes', *Genome Res* (2004) 14, 1911; Perreault, J., Noel, J.-F., Briere, B. et al. 'Retropseudogenes derived from the human Ro/SS-A autoantigen-associated hY RNAs', *Nucleic Acids Res* (2005) 33, 2032; Weber, M.J. 'Mammalian small nucleolar RNAs are mobile genetic elements', *PLoS Genet* (2006) 2, e205; Luo, Y. and Li S. 'Genome-sized analyses of retrogenes derived from the human box H/ACA snoRNAs', *Nucleic Acids Res* (2007) 35, 559.

45 Burki and Kaessmann *op. cit.*, (15).

46 Marques, A.C., Dupanloup, I., Vinckenbosch, N. et al. 'Emergence of young human genes after a burst of retroposition in primates', *PLoS Biol* (2005) 3, e357 [see Supporting Information on the journal website]; Vinckenbosch, N., Dupanloup, I. and Kaessmann, H. 'Evolutionary fate of retroposed gene copies in the human genome', *Proc Natl Acad Sci USA* (2006) 103, 3220; Bradley, J., Baltus, A., Skaletsky, H. et al. 'An X-to-autosome retrogene is required for spermatogenesis in mice', *Nature Genet* (2004) 8, 872.

47 from Marques et al. *op. cit.*, (46).

tree shrews, rabbits and rodents), Laurasiatheria (including hoofed animals, whales, carnivores, bats), Afrotheria (including elephants and aardvarks), and Xenarthra (sloths, armadillos).⁴⁸ The former two groups constitute the Boreoeutheria, and the latter the Atlantogenata.

Table 2. Transposable elements shared in the genomes of humans and rodents ⁴⁹

rodent sharing an insert	insert	number	location
mouse, rat	MER34D	1	<i>SPAM-1</i> gene
mouse	LINE-1	1	<i>ERCC1</i> gene
mouse	MER33	1	interferon- γ gene
mouse	MIR	9	<i>RUNX3</i> gene
mouse, rat, guinea pig	MIR	1	<i>zfOC1</i> gene
mouse, rat	MLT1A0	3	not specified
	LIMA9	1	
mouse	snoRNA	many	many

Recent reports have identified TE inserts that are shared by humans and species outside the primate order, in particular, rodents (Table 2). In some instances, the boundaries between the flanking DNA and the inserted element are conserved in different species (Figure 5). Computer analyses of human and mouse genomes indicate that many instances of ancient parasitic elements are common to both species. Such shared genetic fossils were inserted into the genomes of primate-rodent ancestors, thus establishing the validity of the Euarchontoglires grouping of mammals.⁵⁰ Primates and rodents are monophyletic.⁵¹

48 Murphy, W.J., Eizirik, E., O'Brien, S.J. et al. 'Resolution of the early placental mammal radiation using Bayesian phylogenetics', *Science* (2001) 294, 2348; Binina-Emonds, O.R.P, Cardillo, M., Jones, K.E. et al. 'The delayed rise of present-day mammals', *Nature* 446 (2007), 507.

49 Dunn, C.A. and Mager, D.L. 'Transcription of the human and rodent *SPAM1* / *PH-20* genes initiates within an ancient endogenous retrovirus', *BMC Genomics* (2005) 6, 47; Wilson, M.D., Rutan, C.C., Koop, B.F. and Glickman, B.W. 'ERCC1: a comparative genomic perspective', *Environ Mol Mutag* (2001) 38, 209; Ackerman, H., Udalova, I., Hull, J. and Kwiatkowski, D. 'Evolution of a polymorphic regulatory element in interferon- γ through transposition and mutation', *Mol Biol Evol* (2002) 19, 884; Bangsow, C., Rubins, N., Glusman, G. et al. 'The *RUNX3* gene – sequence, structure and regulated expression', *Gene* (2001) 279, 221; Hughes, D.C. 'MIRs as agents of mammalian gene evolution', *Trends Genet* (2000) 16, 60; Thomas, J.W., Touchman, J.W., Blakesley, R.W. et al. 'Comparative analyses of multi-species sequences from targeted genomic regions', *Nature* (2003) 424, 788. The data are from 'Supplementary information' on the *Nature* website. For shared snoRNA retrogenes, see Weber *op. cit.*, (44) and Luo and Li *op. cit.*, (44).

50 Silva, J.C., Shabalina, S.A., Harris, D.G. et al. 'Conserved fragments of transposable elements in intergenic regions: evidence for widespread recruitment of MIR- and L2-derived sequences within the mouse and human genomes', *Genet Res Camb* (2003) 82, 1; Zhu, L., Swergold, G.D. and Seldin, M.F. 'Examination of sequence homology between human chromosome 20 and the mouse genome: intense conservation of many genomic elements', *Hum Genet* (2003) 113, 60.

51 There are two branches within the Euarchontoglires; one leads to primates, flying lemurs and tree shrews, and has been demonstrated by 5 TE inserts; the other consists of rodents and rabbits, and has been demonstrated by 9 shared inserts. see Kriegs, J.O., Churakov, G., Jurka, J. et al. 'Evolutionary history of 7SL RNA-derived SINEs in supraprimates', *Trends Genet* (2007) 23, 158.

A MIR element that inserted into the DNA of a primate-rodent ancestor

human	...AAAAATT [GGTTTGATTCT...AATGAGAACA]TTAGGCTAAA...
guinea pig	...AAAAATT [GGTTTGATTCT...AATGAGGATA]TTGGGCTGAA...
mouse	...GAAAACAT[GGTTTGATTCT...AATGAGGACA]CTGGACTGAA...
rat	...GAAAATT[GGTTTGATTCT...AATGAGGACA]CCGGACTGAA...

A MLT1A0 element that inserted into the DNA of a primate-rodent ancestor

human	...AAATCAT [T__TTTAGT...ACCACTGCA]GTCACCTTAGAGG...
baboon	...AAATAAT [T__TTTAGT...GCCACTGCA]GTCACCTTAGAGG...
mouse	..._____ [_____...ATCATAGCT]GTTGTCTCAG_____
rat	...AAGCCAC [TGTCCTTAGT...ATTACAGCT]CTTGTTGCAGAAG...
cat	...AGGCCAT _____ CTAGAAT...
dog	...AAGTCAT _____ CTTAGAGT...
cow	...ACATCAT _____ CTTAGAGG...
pig	...ACATCAT _____ CTTAGAGG...

A LINE-1 element that inserted into the DNA of a primate-rodent ancestor

human	...AAAAGCAATCTTTT [ATCCCT...ATACA]AAAAGCAATCTTTC...
baboon	...AAAAGCAATCTTTT [ATCCCT...ATACAA]AAAAGCAATCTTTC...
mouse	..._____TTTC [A_CTCT...A_A]AAGGGGACCTTTC...
rat	..._____TTTC [A_CTCT...AGGGA]AAGGAGAA CTTTC...
cat	...AGAAGC_____TTTA
dog	..._AAGCAATCTTTC
pig	...AAAAGCAXCCTTTC

Figure 5. Inserted elements demonstrating common ancestry of humans and rodents. Three types of inserted elements are depicted. The insert is shown by square brackets; the tell-tale target site duplication (where present) is underlined. The latter two examples show species in which the uninterrupted site is retained. The data are from Hughes (2000) and Thomas et al. (2003),⁵² (Δ: deleted bases; dots [...] indicate that a large amount of sequence is not shown).

It is surprising that such ancient TEs, shared by humans and mice, are still recognisable. Their persistence suggests that they have been domesticated to assume important roles. Sequences in ERV and LINE-1 elements are used to transcribe the *SPAM-1* and *ERCC1* genes. Two processed pseudogenes without protein-coding function have conserved DNA sequences, indicating that they have been maintained by selective pressure. Small RNA inserts function as retrogenes.⁵³

52 Hughes *op. cit.*, (49); Thomas, Touchman, Blakesley et al. *op. cit.*, (49).

53 Dunn and Mager *op. cit.*, (49); Wilson et al. *op. cit.*, (49); Svensson, O., Arvestad, L. and Lagergren, J. 'Genome-wide survey for biologically functional pseudogenes', *PLoS Computational Biol* (2006) 2, e46. The two functional pseudogenes are derived from the *ATX1* and *ATXN7L3* genes that are of unknown function, but associated with neurological diseases; Weber *op. cit.*, (44) and Luo and Li *op. cit.*, (44).

Table 3. Transposable elements shared in the genomes of humans and Laurasiatherians ⁵⁴

Euarchontoglires	Laurasiatheria	insert	location
human, mouse	pig, sheep, cow	Ty3/gypsy	various
human	pig	MIR	TCR α/δ gene
human	pig	LTR, LINE, SINE	SLA genes
human	pig	LTR, LINE, SINE	PRKAG3 gene
human, others	dog	LINE-2	various
human, others	dog	YY2 retrogene	<i>Mbtps2</i> gene

Genome analysis has revealed more distant connections. Humans and mice are descended from Boreoeutherian ancestors shared with Laurasiatherian mammals. Inserted markers of common descent include a family of ‘Ty3/gypsy’ transposons (that now function as genes), LINE-2 elements (that now regulate neural development), and the YY2 retrogene (Table 3). ‘Ancestral repeats’ are ancient TEs that are found throughout the mammals. Databases list 780 classes of these fossils from deep time. In an equivalent segment of DNA from the human, cow and dog genomes 22% of the bases represented shared ancestral repeats.⁵⁵ Highly conserved elements common to Boreoeutherian species may have survived the 100 million years since insertion because they have been co-opted to regulate development. Tens of thousands of these markers have been catalogued.⁵⁶

Placental mammals also are monophyletic. A MIR element in the β -fibrinogen gene has been mapped in twenty diverse species, including humans and elephants.⁵⁷ Software that works through DNA sequences from multiple

54 Lynch, C. and Tristem, M. ‘A co-opted *gypsy*-type LTR-retrotransposon is conserved in the genomes of humans, sheep, mice, and rats’, *Current Biol* (2003) 13, 1518; Brandt, J., Veith, A.M. and Volff, J.-N. ‘A family of neofunctionalized Ty3/gypsy retrotransposon genes in mammalian genomes’, *Cytogenet Genome Res* (2005) 110, 307; Uenishi, H., Hiraiwa, H., Yamamoto, R. et al. ‘Genomic structure around joining segments and constant regions of swine T-cell receptor α/δ TRA/TRD locus’, *Immunology* (2003) 109, 515; Shigenari, A., Ando, A., Renard, C. et al. ‘Nucleotide sequencing analysis of the swine 433-kb genomic segment located between the non-classical and classical SLA class I gene clusters’, *Immunogenetics* (2004) 55, 695; Amarger, V., Erlandsson, R., Pielberg, G. et al. ‘Comparative sequence analysis of the PRKAG3 region between human and pig: evolution of repetitive sequences and potential new exons’, *Cytogenet Genome Res* (2003) 102, 163; Johnson, R., Gamblin, R.J., Ooi, L. et al. ‘Identification of the REST regulon reveals extensive transposable element-mediated binding site duplication’, *Nucleic Acids Res* (2006) 34, 3862; Luo, C., Lu, X., Stubbs, L. and Kim, J. ‘Rapid evolution of a recently transposed transcription factor YY2 in mammalian genomes’, *Genomics* (2006) 87, 348.

55 Liu, G.E., Matukumalli, L., Sonstegard, T.S. et al. ‘Genomic divergences among cattle, dog, and human estimated from large-scale alignments of genomic sequences’, *BMC Genomics* (2006) 7, 140.

56 Lowe, C.B., Bejerano, G. and Haussler, H. ‘Thousands of human mobile element fragments undergo strong purifying selection near developmental genes’, *Proc Natl Acad Sci USA* (2007) 104, 8005; Mikkelsen, T.S., Wakefield, M, J., Aken, B. et al. ‘Genome of the marsupial *Monodelphis domestica* reveals innovation in non-coding sequences’, *Nature* 447 (2007), 167.

57 Yu, L. and Zhang, Y.-P. ‘Evolutionary implications of multiple SINE insertions in an intronic region from diverse mammals’, *Mamm Genome* (2005) 16, 651.

species and reconstructs the original from which they were derived has identified many TEs (comprising 2.7% of the DNA) that have mutated beyond recognition by normal analysis, including an element that inserted into an ancestor of placental mammals.⁵⁸ Systematic studies of ancient TEs have elucidated the relationships of the placental mammals and demonstrated the monophyly of all major groups (Figure 6). In many cases TSDs and unoccupied target sequences are still recognisable (Figure 7).

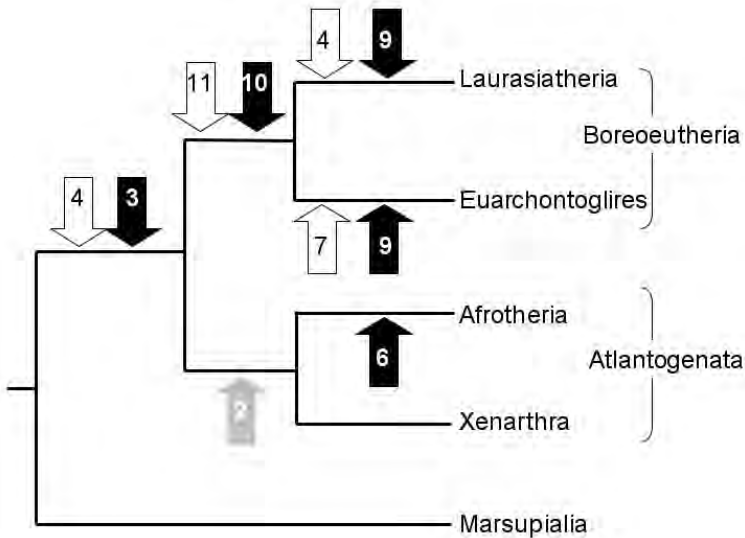

Figure 6. Mammalian evolution as determined by the distribution of TEs. The data are from Kriegs et al. (2006) (white arrows), Nishihara et al. (2006) (black arrows), and Murphy et al. (2007) (grey arrow).⁵⁹ Numerals indicate the number of identified TEs that inserted into mammalian DNA at the time indicated.

Some ancestral repeats are highly conserved beyond placental mammals. Their sequences are under strong selective pressure to stay the way they are; evidence that they perform vital tasks. MIR elements are scattered throughout our genome and those of other mammals. Three of these ancient inserts have

58 Blanchette, M., Green, E.D., Miller, W. and Haussler, D. 'Reconstructing large regions of an ancestral mammalian genome in silico', *Genome Res* (2004) 14, 2413.

59 Kriegs, J.O., Churakov, G., Kiefmann, M. et al. 'Retroposed elements as archives for the evolutionary history of placental mammals', *PLoS Biol* (2006) 4, 537; Nishihara, H., Hasegawa, M. and Okada, N. 'Pegasoferae, an unexpected mammalian clade revealed by tracking ancient retroposon insertions', *Proc Natl Acad Sci USA* (2006) 103, 9929. A series of striking sequence alignments are available on the PNAS website. Murphy, M.J., Pringle, T.H., Crider, T.A. et al. 'Using genomic data to unravel the root of the placental mammal phylogeny', *Genome Res* (2007) 17, 413.

been incorporated into gene sequences and are shared by humans and opossums (a marsupial); another is shared by humans and the most distantly related mammal, the platypus.⁶⁰

1. A L1MB element common to Boreoeutherians

Euarchontoglires

human ...G ACCAGGAAACTTTT [L1MB] TA CCAGGAA ACTTTT...
 flying lemur ...G ACCAGGAAACTTTT [L1MB] TA CCAGGAA ATTTTT...
 tree shrew ...A ACCA_____TTTT [L1MB] TA TCAGGAA AATTTT...
 mouse ...A TCTGTGAAG_TTT_[L1MB] TC CCTGTGA AGTTTT...
 rabbit ...G GCCAGGAAACTTT_[L1MB] TA CAAGGAACATTTTT...

Laurasiatheria

cow ...C ACCAGGAAACTGTG [L1MB] TC TCAGGAA ACTTCT...
 horse ...T TCCAGAAAAC TTTT [L1MB]__ CCAGGAA AGTT_T...
 cat ...TA ACTGGGAAACTTTT [L1MB] TA CCAGGAA ACTTTT...
 dog ...TA ACTGGGAAACTGT_[L1MB] TA CCAGGAA ACTTAT...
 bat ...T ACCAGGATACTTTT [L1MB] TA CCAGGAA ACTTTT...
 shrew ...T GCCAGGAAACTTTT [L1MB] CAACCAAAAA ACTTTT...

Afrotheria

elephant ...T ACCTGGAAACTTTT...
 manatee ...T ACCTGGAAACTTCT...
 hyrax ...T ACTTGGAAACTTTT...
 tenrec ..._ AC_TG_AAA_____...

Xenarthra

Armadillo ...T A_____AAATTTGT...

2. A L1MB element common to placental mammals

Euarchontoglires	human	...ATTTAGTGT[L1MB] TGTTAATTT...
	mouse	...TATTAATCT[L1MB] TGCTAATTT...
Laurasiatheria	dog	...AAGTAGTGC[L1MB] GGTTCATTT...
Afrotheria	tenrec	...AGCCAACCC[L1MB] TATGAACTC...
Xenarthra	armadillo	...TGTTAATCT[L1MB] TGTTAATCA...
Marsupialia	opossum	...TGCTAATCA...

Figure 7. Inserted elements demonstrating common ancestry of boreoeutherian and placental mammals. Sequences flanking the inserts are the TSDs. Uninterrupted target sites are present in Afrotheria and Xenarthra (upper insert) and marsupials (lower insert).⁶¹

A study of species for which whole genome sequences are available (human, rat, mouse, dog) identified 115 shared TEs that have a run of 50 identical bases. ‘MER121’ elements (909 copies in the human genome) are extraordinarily

60 Krull, M., Petrusma, M., Makalowski, M. et al. ‘Functional persistence of exonised mammalian-wide interspersed repeat elements (MIRs)’, *Genome Res* (2007) 17, 1139.

61 See above (59).

ily conserved: approximately 80% of these unique inserts are found in each of the four species, and in the opossum. 'AmnSINE1' elements ($\geq 1,000$ copies in the human genome) include 100 highly conserved inserts that are found also in chimps, rodents, dogs, and opossums. Two inserts are present at equivalent positions in the DNA of humans and chickens. Virtually all 'LF-SINE' elements (245 copies in the human genome) pre-date the separation of the placental and marsupial lineages. One LF-SINE insert, present in mammals, chickens and frogs, has survived the eons since it was inserted because it has been co-opted to provide essential regulation of a developmental gene.⁶²

The sequencing of the opossum genome has unearthed 83 new classes of TE. Many individual inserts of the 'MER131' class are shared by humans and opossums (on the basis that they are found in the same genetic location; TSDs disappeared long ago). Of the 68 inserts most conserved between human and opossum, 38 appear to be present in the chicken.⁶³

'Palaeogenomics' is burgeoning. The fossil hunters have access to rich resources of genomes, ancestral repeats, and software. We have inherited three million TEs that inserted themselves into the DNA of now extinct mammals. Each insertion was a unique event, but the resulting insert is now a characteristic feature of the human genome, and in most cases, of the genomes of many other species too. We and the other mammals are monophyletic, derived from a single lineage of ancestors that accumulated TEs even as they scurried around under the feet of dinosaurs. And yet retroviral and transpositional insertions are but one of many classes of mutational events that have established the route of human evolution – and that have made us what we are.⁶⁴

62 Cooper, G.M., Stone, E.A., Asimenos, G. et al. 'Distribution and intensity of constraint in mammalian genomic sequence', *Genome Res* (2005) 15, 901; Kamal, M., Xie, X. and Lander, E.S. 'A large family of ancient repeat elements in the human genome is under strong selection', *Proc Natl Acad Sci USA* (2006) 103, 2740; Nishihara, H., Smit, A.F.A. and Okada, N. 'Functional noncoding sequences derived from SINEs in the mammalian genome', *Genome Res* (2006) 16, 864; Xie, X., Kamal, M. and Lander, E.S. 'A family of conserved noncoding elements derived from an ancient transposable element', *Proc Natl Acad Sci USA* (2006) 103, 11659; Bejerano, G., Lowe, C.B., Ahituv, N. et al. 'A distal enhancer and an ultraconserved exon are derived from a novel retroposon', *Nature* (2006) 441, 87. Members of this class of retrotransposon are also present in the coelacanth, but none of the inserts in the coelacanth is inserted in the same place as any of the human copies. Nevertheless, TSDs and polyA tails indicate that LF-SINEs copy-and-paste by the standard SINE strategy.

63 For the opossum genome, see Mikkelsen et al. *op. cit.*, (56); for ancient transposable elements, see Gentles, A.J., Wakefield, M.J., Kohany, O. et al. 'Evolutionary dynamics of transposable elements in the short-tailed opossum *Monodelphis domestica*', *Genome Res* 17 (2007), 992.

64 Other clonal markers include duplications, deletions, inversions, and other types of insertion mechanisms: Matthee, C.A., Eick, G., Willows-Munro, S. et al. 'Indel evolution of mammalian introns and the utility of non-coding nuclear markers in eutherian phylogenetics', *Mol Phylogenet Evol* (2007) 42, 827; Chaisson, M.J., Raphael, B.J. and Pevzner, P.A. 'Microinversions in mammalian evolution', *Proc Natl Acad Sci USA* (2006) 103, 19824; Hazkani-Covo, E. and Graur, D. 'A comparative analysis of numt evolution in human and chimpanzee', *Mol Biol Evol* (2007) 24, 13.

Integrating histories

Evolution is history, and the DNA we carry is an authoritative historical record. The concept that humanity has arisen by historical process elicits strong and opposing reactions from some people. Intelligent Design theorists assume that the historical development of biological form and function cannot be described in authentically biological terms, and import teleological considerations *into* science.⁶⁵ Materialists propound the metaphysical creed that the scientific study of evolutionary history excludes considerations of purpose *beyond* science.⁶⁶

The Bible introduces humanity in exalted terms as *Homo divinus*, the creature that bears God's likeness. Genomic research has shown that our phylogenetic and ontogenetic development occurred according to a genetic blueprint that has been cobbled together by the accumulation of agents that replicate haphazardly, insert randomly, and (in the short term) act as pathogenic insertional mutagens. Are these perspectives incongruous?

Many parallels have been recognised between the historical bases of biology and of Christian faith. Fifty years ago, Raven stated:

It is one of the ironies of history that Christendom which by its own Scriptures was committed to belief in an ever-working God (e.g. John 5:17) in a progressive revelation still incomplete (John 16:13), in suffering as the characteristic of the creature (Rom. 8: 18-23) and the means to perfection (Hebr. 2:10), and in fuller life as the divine purpose (John 10: 10) should have so signally failed to maintain this belief when faced with the challenge of Darwinism.⁶⁷

We may learn from Raven. The 'incongruity' represented by the inauspicious genetic origins of *Homo divinus* reflects a recurring theme in Scripture. Israelite nationhood arose out of sheer obscurity (Deut.7:7), slavery (Exod.2:20) and exile (Isa.41:17-20). Redemption came from the shame of the Crucifixion (1Cor.1:23-24). Spiritual life arises from death (Eph.2:1-10), growth from adversity (James 1:2-4), and glory from suffering (Rom.8:17). The Gospel has been entrusted to nondescript 'vessels' (2Cor.4:7). God consistently creates what is new and magnificent from what is old and flawed.⁶⁸ We should not be surprised that God has created his 'image' by a history that incorporates the random activities of genetic parasites.

God's creative work in biological history and in personal human history incorporates in its process the freedoms of genetic process and human auton-

65 ID theorists generally reject speciation, common ancestry, 'macroevolution' and the role of genetic mechanism in the development of complexity. See Dembski, W.A., ed. *Darwin's Nemesis*, Downer's Grove and Leicester: IVP (2006).

66 Dawkins, R. 'God's Utility Function'. *Scientific American* (1995) 273 (5), 62.

67 Raven, C.E. *Christianity and Science*, London: Lutterworth Press (1955), p.31.

68 As developed by Konig, A. *New and Greater Things*, Pretoria: UNISA (1988).

omy. The theologian B.B. Warfield, in welcoming evolutionary findings, developed the concept of ‘concursum’. This stressed that ‘the products of natural history could be the consequence – at the same time – of both natural forces and divine action’. Evolution, the writing of Scripture and the work of salvation are the products of both natural forces and divine action.⁶⁹

Biology is natural history. ‘Earth is the planet with genetic natural history, several billion years worth, and that genesis is stored in genes.’⁷⁰ In approaching this natural history we find the ancient Hebrews to be fellow-travellers. They sought to understand life’s mysteries in ‘the unique and unrepeatable facts of history’.⁷¹ Thus ‘natural historians’ should find the biblical perspective congenial to their thinking. ‘The Old Testament is distinguished from most other religious books by its great emphasis on the facts of history.’⁷² It is ‘unique in the attention it gives to human history... The God of ancient Israel primarily has to do with the course of human history, and in so far as he can be defined at all it is in terms of history.’⁷³

Konig stated that ‘No other religion is so out-and-out historical as Christianity, grafted onto the stem of Israel’s faith. The view of history as a succession of cohesive events directed towards a goal in the future – it was not without reason that this originated in Israel; it was the consequence of the ways in which her God dealt with his people.’⁷⁴

Interpreting history

The Hebrew Scriptures were interpretations of history. Drane writes, ‘The Old Testament faith emerged from the corporate history of Israel’s people.’⁷⁵ Israel’s prophets did not write collections of brute facts. ‘They were interpretations and applications of the meaning of history.’⁷⁶

Israel’s faith differed from contemporaneous world religions.

This unique ‘other’ movement was not the creation of any human mind, but was a corporate interpretation of historical fact. This interpretation, of all the religions of the world, is alone based on fact... This interpretation is so strange, so utterly different, from the thoughts of any other human being at any time in history, that the reader is compelled to ask whether it does not actually come from the mind of God...⁷⁷

69 Livingstone, D.N. and Noll, M.A. ‘B. B. Warfield (1851-1921): a biblical inerrantist as evolutionist’, *Isis* (2000) 91, 283.

70 Rolston III, H. *Genesis, Genesis and God*, Cambridge: Cambridge University Press (1999), p.50.

71 Drane, J. *Old Testament Story*, Tring: Lion (1983), pp.30-31.

72 Drane, J. *Old Testament Faith*, Tring: Lion (1986), p.23.

73 Turner, H. *The Roots of Science*, Auckland: The DeepSight Trust (1998), p.68; Turner here was quoting Lloyd Geering, a professor of Religious Studies who does not favour a Christian position.

74 Konig, *op. cit.*, (68), p.171.

75 Drane, *op. cit.*, (72), p.78; see also p.46.

76 Drane, *op. cit.*, (71), pp.22-24, 145-148.

77 Knight, G.A.F. *I Am: This is My Name*, Grand Rapids: Eerdmans (1983), p.4.

Biblical theology remains 'first of all history'.⁷⁸ This necessitates theological engagement with evolutionary history. To James Iverach, evolution reflected 'the orderly succession of causes which work out the rational purposes of God. This was not a religious alternative to a scientific conception of the world, but an interpretation of scientific findings from a religious point of view.'⁷⁹ Herein lie the roots of the disparate assessments of evolution. To someone whose mind has been conditioned by Israel's history, evolution is part of a larger and significant story. To minds unaccustomed to seeing an overarching directionality in human history, biological history is a meaningless sequence of happenstance.

The Greeks are often considered the pioneers of history writing, but between 'the Greek and Hebrew writer lies that one point of difference which marks the essential uniqueness of Old Testament thinking'. The Greek writers discerned cause-and-effect relationships, but not meaning in the events they described. The biblical historians emphasised that 'history had a meaning, and that all that happened was leading forward to an ultimate goal'.⁸⁰ Israel came to see history in ever more comprehensive terms: 'they experienced every phase of their history as the accomplishing of God's purposes with them'. Indeed the 'consummation of history would occur when God had achieved his goal with all mankind'.⁸¹

This hermeneutic must inform our understanding of evolutionary history.

- God was *involved* in history. God's very name, inadequately translated 'I AM', means that he is active. 'This is radically opposed to the static, withdrawn, sufficient-unto-himself being of Greek philosophy.'⁸²
- God was in *control* of history. Israel's prophets were united by 'the knowledge that history was in God's control',⁸³ that history 'was in the hands of the *I AM with you*' and was heading forwards to an ultimate goal.⁸⁴ Both nature and history were the work of God's word.⁸⁵
- God was *creator* of history. Israel came to appreciate that Yahweh was radically different from other gods. He was 'the personal, living Creator God who holds the entire life of his people in his hands, who indeed creates their history... God's acts control, indeed create, history.'⁸⁶ Israel saw

78 Blocher, H. *In the Beginning*, Leicester: IVP (1984), p.24. Thus we may not oppose theology and history, or 'belief' and 'knowledge'.

79 Moore, J.R. *The Post-Darwinian Controversies*, Cambridge: CUP (1979), p.254.

80 Knight, *op. cit.*, (77), pp.42-44.

81 Konig, A. *Here Am I*, Grand Rapids: Eerdmans, and London: Marshall Morgan and Scott (1982), p.125.

82 Konig, *op. cit.*, (81), p.67; also pp.78, 93, 123-124; 179.

83 Drane, *op. cit.*, (71), p.30.

84 Knight, *op. cit.*, (77), p.43.

85 Konig, *op. cit.*, (81), p.29; *op. cit.*, (68), pp.52-53.

86 Konig, *op. cit.*, (81), pp.4, 6; also pp.37, 88, 95; 'God reveals himself in the history that he creates', p.182; also *op. cit.*, (68), p.67.

in her turbulent story the creative activity of the ever-working God. Analogously, we may perceive in the randomness of genetic process a divinely written history. God is creator of humanity at least partly because he is the creator of humanity's phylogenetic history. Following Israel, we should recognise a God who works in the apparent chaos of (genetic) history and transforms it into unprecedented glory.

Alternative interpretations of history

Israel's leaders articulated compelling interpretations of history, but not everyone agreed with them. Jeremiah interpreted Israel's ultimate catastrophe (the destruction of Jerusalem, 587 BC) as being a consequence of the people's rejection of God. Others attributed it to their desertion of the Canaanite 'Queen of Heaven'. History does not yield to wholly unambiguous interpretations.⁸⁷

Dawkins' interpretation of evolutionary history leads him to deny that there is any climax: evolution is not meaningful history. 'Evolution has reached many millions of interim ends (the number of surviving species at the time of observation), and there is no reason other than vanity... to designate any one as more privileged or climactic than any other.... The historian must beware of stringing together a narrative that seems, even to the smallest degree, to be homing in on a human climax...'⁸⁸

The turbulence and sufferings of Israel's history likewise may suggest that her story was meaningless. But the Christian world-view is based on the conviction that this chaotic history converged climactically on Christ. Jesus explained how 'all the Scriptures, beginning with the books of Moses and the writing of all the prophets' anticipated him: 'everything written about me in the Law of Moses, the writings of the prophets and the Psalms had to come true' (Lk.24:27, 44). The paradigm by which the New Testament writers saw Israel's chaotic history fulfilled in Christ provides the hermeneutic key by which we may see in the winding evolutionary route leading to humanity that same divine purpose.

Dawkins sees the suffering in nature as evidence that 'the universe that we observe has precisely the properties we should expect if there is, at bottom, no design, no purpose, no evil and no good, nothing but pitiless indifference'.⁸⁹ Indeed it is not easy to discern God's action in history given the concrete situation of our world. But history is not simply the mechanical unfolding of a pre-determined plan. God does indeed achieve his purposes in history, 'yet he does not do or occasion *everything* in history'. In fact, history is the resultant of the wholly consistent goodness of God and the arbitrary and selfish choices of humanity: 'history is formed by both the faithfulness of God and the unfaith-

87 Konig, *op. cit.*, (81), pp.56-57.

88 Dawkins, R. *The Ancestor's Tale*, London: Weidenfeld and Nicolson (2004), pp.10-12.

89 Dawkins *op. cit.*, (66).

fulness of man'. Genuine history arises from the contributions of freely acting partners. Much that happens is not the will of God. 'The greater part of history (that of Israel, the church, the world) is in fact a violation of the will of God...'⁹⁰

Evolutionary history is the resultant of both the genuine freedom that God has given to creation, and the faithful way by which God sustains creation. There is a fruitful antithetical interrelation between 'chance and necessity'. 'Chance' represents freedom (random insertional mutagenic events). 'Necessity' represents the way by which randomly generated novelty is constrained along specified paths by the consistent and rational structure of reality, ordained and faithfully sustained by God.⁹¹

How can we see a *loving* God in the carnage of biological and human history? The whole of biblical history, climaxing at Easter, demonstrates God's love. 'Against these facts, against history, a theory must surrender... throughout the long history of Israel and the church, God poured out his love on people who were not worthy of it... The love of God, or rather the God of love, sustains and controls all history.' Jesus Christ is the 'explicative history' of God is love. God's covenant with Israel must be seen as exemplifying the history of God's universal covenant with the world.⁹²

Dawkins dismisses the history of Jesus as 'parochial'.⁹³ That God's definitive redemptive act for humanity and indeed for the cosmos (Rom.8:19f; Eph.1:10; Col.1:20; Heb.1:1-3) should be effected by one individual, Jesus of Nazareth, appears incongruous (the 'scandal of particularity').⁹⁴ But history runs on particulars. The role of Alu insertions in human evolution has provoked the statement that evolution is based partly on the occurrence of unique events, 'which is at the outer edge of science'.⁹⁵ A particular TE that characterises every Euar-chontoglire mammal (human, mouse, rabbit...) arose in one reproductive cell. Evolutionary history is parochial, particular, the outcome of unique happenings. That the story of redemption should share this character is testimony to the authenticity of the history that God makes with his creation.

Eschatological history

Certainty regarding the interpretation of history awaits the completed story.

90 Konig, *op. cit.*, (81), pp.111, 127-130 (after Preuss, Pannenberg).

91 Polkinghorne J. *Science and Creation*, London: SPCK (1988), pp.47-49 and *One World*, London: SPCK (1986), pp.53-54. This principle is illustrated by Conway Morris, S. *Inevitable Humans in a Lonely Universe*, Cambridge: CUP (2003), and Vermeij, G.J. 'Historical contingency and the purported uniqueness of evolutionary innovations', *Proc Natl Acad Sci USA* (2006) 103, 1804.

92 Konig, *op. cit.*, (81), pp.37, 43-44.

93 Debate 'God vs Science', *TIME* (2006) November 13, 32. Note the dishonest title given to the feature. It is ironic that Dawkins denies the historical basis of Christianity in the same way as Creationism/ID theory denies the historical basis of biology.

94 Polkinghorne, J. *Science and Christian Belief*, London: SPCK (1994), p.186.

95 Gibbons, R., Dugaiczky, L.J., Girke, T. et al. 'Distinguishing humans from great apes with AluYb8 repeats', *J Mol Biol* (2004) 339, 721.

Jeremiah asserted that events in the future would vindicate his message. We cannot pass judgment on God's action in history until we have seen the consummation of history. God has made history with a goal in mind.⁹⁶

To Konig, both

the history of creation and the history of Israel, are, then, 'eschatological history', and in a twofold sense. Eschatology can mean 'expectation of the future'. In this sense both the history of creation and that of Israel direct our gaze to the future; something must still lie ahead because we cannot remain satisfied with these two histories. But eschatology also – and especially – has to do with purpose, with the attaining of a goal. And in this sense too both these histories are eschatological history.⁹⁷

Biological and human history must be interpreted in terms of God's commitment to his creation, and in terms of his eschatological programme.

The 'history of Jesus' is required to interpret history fully. The New Testament writers indicate that 'there is a special relationship between Christ and the *entire history* of the world'. The goal of creation is not be attained apart from Christ. Konig concludes 'that Jesus is the last, the end, and above all the goal of creation, that creation is therefore aligned toward him and directed to him, and that, united under his lordship, it will ultimately achieve harmony'.⁹⁸

History then is a unity. Biological history with its motif of chance and necessity has reached its climax in the advent of humanity, the (provisional) image of God (Gen.1:26-27, 9:6; James 3:9). Israel's history with its motif of human unfaithfulness and divine faithfulness has reached its climax in the advent of Christ, the exact Image of God (2 Cor.4:4; Col.1:15; Heb.1:3). The history of Jesus with its motif of suffering and glory⁹⁹ will reach its climax in the conferral of Christ's perfect image on humanity (1Cor.15:49; 1Jn.3:2; Phil.3:21). History must be judged by its consummation – a redeemed humanity in a transformed creation.

Graeme Finlay is a cell biologist in the Auckland Cancer Society Research Centre and lectures in general pathology at the University of Auckland, New Zealand.

96 The future events being the destruction of the Israelites while in their refuge in Egypt, and of Pharaoh Hophra along with them (Jer. 44:26-30); Konig, *op. cit.*, (81), pp.56-57; 206.

97 Konig, *op. cit.*, (68), p.34.

98 Konig, A. *The Eclipse of Christ in Eschatology*, Grand Rapids: Eerdmans and Blackwood: New Creation Publications (1989), ch.1, esp. pp.30, 37; also 40, 46.

99 The theme of 'suffering and glory' shares the property with the other motifs that it describes a purposive history arising from events not caused by God ('suffering') in the context of God's directing faithfulness ('glory'); see Lk.24:26; Jn.12:27-28; 2Cor.4:17; Rom.8:17-18; 1Pet.1:6-7, 11; 4:12-14; 5:1, 9-10; Heb.2:9-10.

Copyright of Science & Christian Belief is the property of Paternoster Periodicals and its content may not be copied or emailed to multiple sites or posted to a listserv without the copyright holder's express written permission. However, users may print, download, or email articles for individual use.